

VTS-991

* Please see page 2 for instructions.

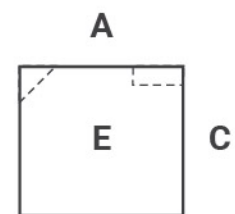
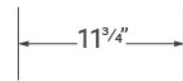
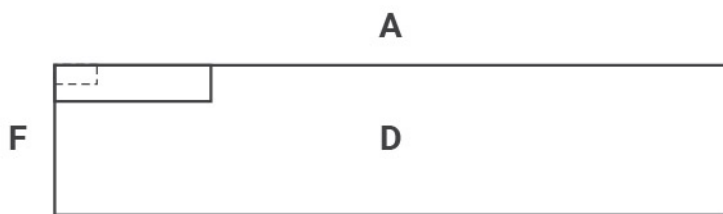
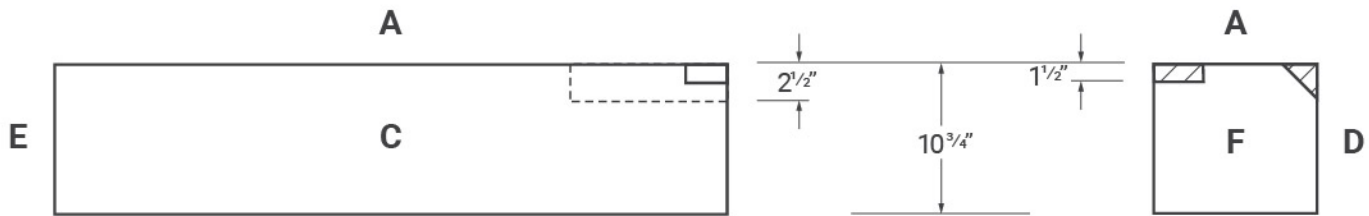
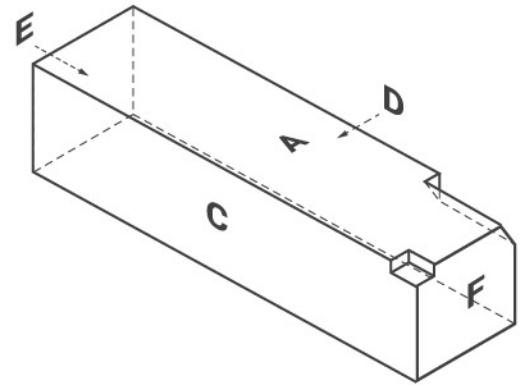
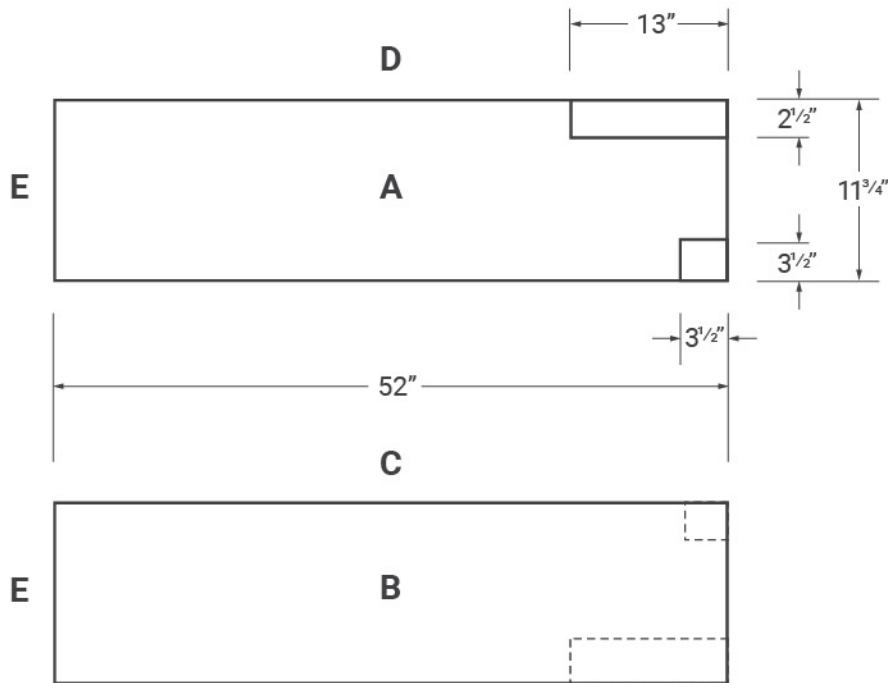

Customer Name: _____

Order #: _____ (Place order before submitting drawing)

Customer Name: _____

Order #: _____ (Place order before submitting drawing)

Total # of custom fittings: _____

Phone: _____

Email: _____

Mark fitting types and locations, then

**scan and email both pages to
customtanks@vintagerv.com**

For help, email or call **800-644-4620**

RULES FOR DRAWING

Indicate on the tank diagram where you want your fittings. We require a clear drawing from you before we can begin fabrication. If your drawing is not clear, we will need to ask you to redraw it so that there are no ambiguities.

Follow the rules below to avoid unnecessary delays:

All fittings will have female threads. The fittings can protrude from the tank or be recessed flush into the tank. You may specify any of the following fittings for this tank:

- 1/2" flush recessed
- 1/2" protruding
- 1-1/2" flush recessed
- 1-1/2" protruding
- 3" flush recessed
- 3" protruding

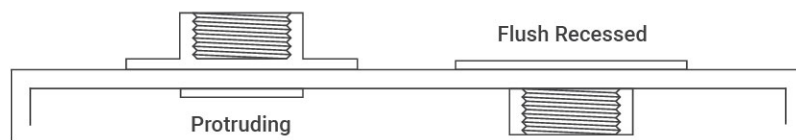

If you do not label your fittings as either "flush" or "protruding," you consent to us choosing for you.

Draw fittings on visible faces of diagram only. Do not indicate hidden fittings on back sides of tanks. We provide views of all faces to make it easy to indicate all fittings.

Indicate distance in inches from the center of each fitting to two adjacent edges of the tank.

Because all spin welded fittings have flanges around their perimeters, threads cannot be installed immediately along tank edges. If you would like a fitting installed as close as possible to an edge or corner, simply write "as close to _____ as possible" next to the fitting.

I understand customized tanks are not returnable.

Signature: _____

Date: _____